

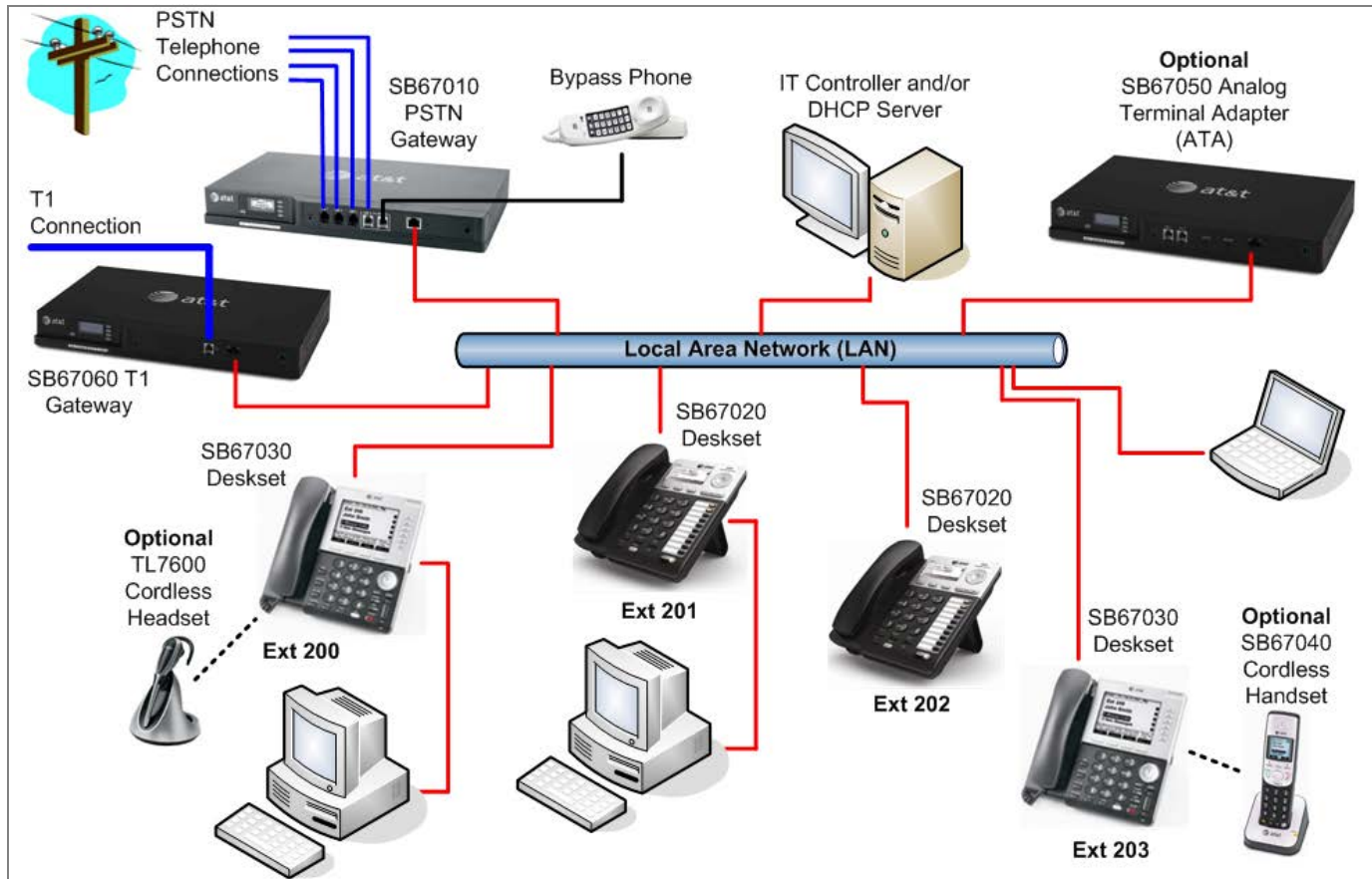

# Synapse™ Installation Guide

To install the Synapse system correctly, follow the Recommended Installation Sequence described on the following pages. If you have non-Synapse devices that you want to attach to the system, you will need an AT&T SB67050 Analog Terminal Adapter (ATA). Figure 1 illustrates a sample system with outside telephone connections in **blue** and ethernet cables in **red**.



**Figure 1. Sample System**

## Recommended Installation Sequence

1. Prepare your site for installation.

 See “Site Preparation” in the Synapse Administrator’s Guide at [www.telephones.att.com/synapseguides](http://www.telephones.att.com/synapseguides).

2. Install the Gateways.

 See “Gateway Installation” in the Synapse Administrator’s Guide.

3. If you have only one Gateway, install the first Deskset.

 See “Deskset Installation” in the Synapse Administrator’s Guide.

4. **Optional:** Configure the Dial Plan Settings and Direct Inward Dialing (DID). Unless you do this, the first Deskset is assigned the default extension number 200 and the subsequent Desksets are assigned sequential three-digit extension numbers starting with 201 and without DID numbers.

 To use DID, see “Dial Plan Settings” and “[T1] Direct Inward Dial” in the Synapse Administrator’s Guide.

Use the WebUI to change the Dial Plan Settings if you want the first extension number to be something other than 200, possibly to correspond to the DID numbers, or if you want the parked-call extension numbers to start with a digit other than 1.

After changing the Number of Digits and Default Phone Extension Prefix of the first Deskset you installed, manually change the first Deskset extension number, and manually set its DID number.

5. Install the other Desksets.

 See “Deskset Installation” in the Synapse Administrator’s Guide.

6. Optional: Install the AT&T SB67050 Analog Terminal Adapter (ATA).

 See “[ATA] Optional ATA Installation” in the Synapse Administrator’s Guide.

7. Continue configuring the system using the WebUI.

 See “System Configuration” in the Synapse Administrator’s Guide.

8. Complete post-installation tasks.

- Ask all users to record their user names on their Desksets.



See “Name Recording” in the AT&T SB67030 Deskset and Accessories User’s Guide or the AT&T SB67020 Deskset User’s Guide at [www.telephones.att.com/synapseguides](http://www.telephones.att.com/synapseguides).

- Distribute and register any Cordless Handsets or Headsets.



See “[Handset] SB67040 Cordless Handset Installation” and “[Headset] TL7600 Cordless Headset Installation” in the Synapse Administrator’s Guide.

- Check for software upgrades and register your Synapse system products.



See “Update Device” and “Product Registration” in the Synapse Administrator’s Guide.

## System Devices

This document provides an overview of the following Synapse devices. Each system must include at least one Gateway — either a PSTN or T1 Gateway. Four PSTN Gateways can be combined with a T1 Gateway to support up to 39 telephone numbers.

1. **AT&T SB67010 PSTN Gateway** — Each PSTN Gateway provides access to up to four analog telephone lines. The system can have up to four PSTN Gateways, supporting up to 16 telephone lines.
2. **AT&T SB67060 T1 Gateway** — The T1 Gateway supports the T1 PRI (Primary Rate Interface) that can provide access to up to 23 voice channels, to support up to 23 simultaneous calls. The system can have only one T1 Gateway.
3. **AT&T SB67020 Deskset** — A Deskset with a standard screen and Programmable Feature Keys. The system can have up to 100 Desksets, and you can combine SB67020 and SB67030 Desksets.
4. **AT&T SB67030 Deskset** — A Deskset with a large screen and a DECT 6.0 radio to host the optional Cordless Handset and Headset accessories. The system can have up to 100 Desksets, and you can combine SB67030 and SB67020 Desksets.
5. **AT&T SB67040 Cordless Accessory Handset** (Optional, requires SB67030 Deskset). The Cordless Handset duplicates many of the SB67030 Deskset features and provides a high degree of mobility.
6. **AT&T TL7600 Cordless Accessory Headset** (Optional, requires SB67030 Deskset). The Headset lets you work while you talk.
7. **AT&T SB67050 Analog Terminal Adapter (ATA – Optional)** — The ATA allows the integration of analog telephones, a fax machine, overhead paging equipment, and a music-on-hold source into the Synapse system. It also provides Group Mailboxes to allow different people to access the same Mailbox. The system can have only one ATA.



8. **Web User Interface (WebUI)** — The WebUI provides the ability to customize your system for your business from a PC that is on the same Local Area Network. The WebUI resides on the Gateways, ATA, and Desksets, and is updated with device software updates.



To complete the setup process, see the Synapse Administrator's Guide at [www.telephones.att.com/synapseguides](http://www.telephones.att.com/synapseguides).



**NOTE**

You can register only one AT&T SB67040 Cordless Handset and only one AT&T TL7600 Cordless Headset to a SB67030 Deskset. Up to five SB67030 Desksets can have cordless accessories, although this number can increase depending on your office environment. Factors such as proximity of Desksets, number of simultaneous calls, and structural obstacles affect how many Desksets can have cordless accessories. When a SB67030 Deskset has cordless accessories, they are all part of the same extension, and only one extension device can be used at a time.

at&t 8

Logout  
Extension Settings  
Basic Settings  
Extension Directory  
Quick Dial Keys  
Help

**Basic Settings for Extension: 219**

**Extension Name:** Derrick Duhren

**Call Forward All Settings:**

Call Forwarding:  Off  On

Target Type:  Voicemail: Personal

Extension: 218

Outside Phone Number: 2325550176

**Auto Answer Settings:**

Delay: 5 Seconds

**Set Password:**

User Password:

Apply Cancel

All installations require compatible software versions on all devices.

- To determine the software version of Gateways and the ATA, from their idle screens, press **SELECT**, **SELECT**, and then **DOWN**. The software version displays, as shown in Figure 2.
- To determine the SB67020 Deskset software version, press **MENU**, then **4**, and then the  $\nabla$  Navigation key to display the software version as shown in Figure 3.
- To determine the SB67030 Deskset software version, press **MENU**, then **4**. See the P Firmware version as shown in Figure 4.

 To complete the setup process, see the Synapse Administrator's Guide at [www.telephones.att.com/synapseguides](http://www.telephones.att.com/synapseguides).



Downloadable copies of all Synapse documents, including user's and administrator's guides, installation instructions and quick-start guides, are available at [www.telephones.att.com/synapseguides](http://www.telephones.att.com/synapseguides).

You can view Synapse installation videos at [www.telephones.att.com/smb](http://www.telephones.att.com/smb). In the left navigation menu, click on **Customer Support** and then **Demo Videos**.

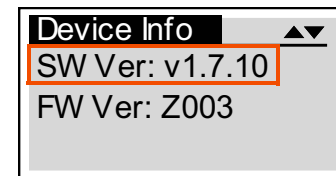

Figure 2. PSTN Gateway Software Version

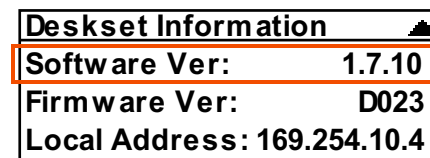

Figure 3. SB67020 Deskset Software Version

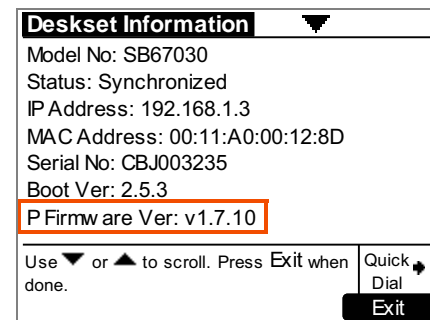

Figure 4. SB67030 Deskset Software Version



[www.telephones.att.com/smb](http://www.telephones.att.com/smb)

© 2010-2011 Advanced American Telephones. All Rights Reserved.  
AT&T and the AT&T logo are trademarks of AT&T Intellectual Property  
licensed to Advanced American Telephones, San Antonio, TX 78219.

Synapse™ is a trademark of Advanced American Telephones.

Printed in China Issue 12.0 2/11